

# Extreme ISF® Process



The Extreme ISF® Process is a suite of chemical and chemical-mechanical surface finishing and polishing technologies capable of removing the extreme surface roughness and surface/near-surface defects inherent to metal AM components while simultaneously improving component performance and appearance.

The Extreme ISF® Process is comprised of two primary process technologies: Chemical Polishing (CP) and Chemical-Mechanical Polishing (CMP). CP and CMP can be used individually or in combination, and are compatible with a wide range of component geometries including lattice structures and complex internal passages (ex. rocket nozzle cooling channels). REM's unique chemically assisted technology is also better able to preserve component features than abrasive or electrochemical processes.

## REM'S EXTREME ISF® Benefits:

- Reduce roughness/waviness
- Remove powder/eliminate FOD
- Remove oxide layers
- Remove support structures
- Increase dynamic fatigue life
- Increase corrosion resistance
- Increase tensile strength
- Increase cleanliness
- Improve flow performance
- Reduce pressure drop

REM Extreme ISF® Processes can meet specific material removal targets, with the capability to hold tolerances up to  $\pm 0.0001$ " ( $\sim 2.5 \mu\text{m}$ ). REM's process technology can produce surface finishes  $< 4 \mu\text{in}$  ( $0.1 \mu\text{m}$ ) Ra, can be used to produce commonly specified legacy component surfaces [ex.  $< 125 \mu\text{in}$  ( $3.2 \mu\text{m}$ )], or can preserve roughness in the form of waviness while eliminating powder from a surface.

## REM'S EXTREME ISF® Alloy Capabilities Include:

- Aluminum Alloys
- Bulk Metallic Glass Alloys
- Copper Alloys
- Nickel Alloys
- Nickel-Chrome Superalloys
- Stainless Steel Alloys
- Steel Alloys
- Titanium Alloys

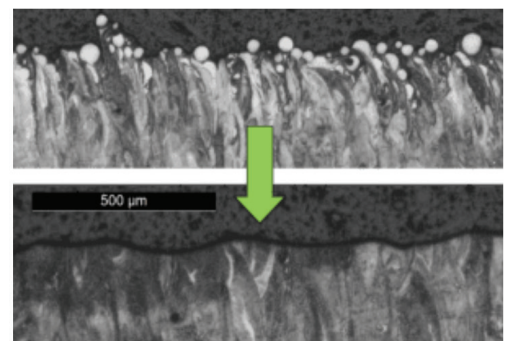

**The Extreme ISF® Process is a robust process technology that is scalable and available via outsourced processing or as a technology installation.**

All sites are ISO 9001:2015 and AS9100:2016 Rev D certified

ISF® and REM logo are registered trademarks of REM Surface Engineering. All rights reserved.



Contact us today to learn more  
or to Start a Project.

[www.remchem.com](http://www.remchem.com)

# Ramp System™ H+ Series

## Extreme ISF® Process Cell

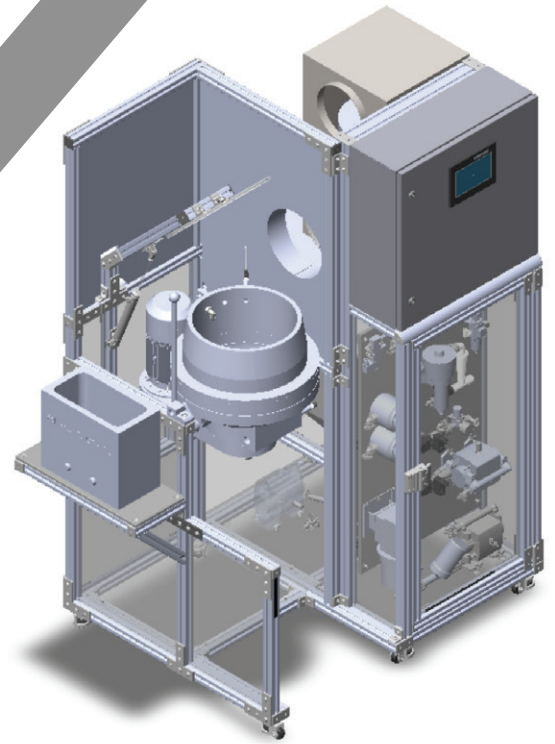

The Ramp System™ H+ Series Extreme ISF® Process Cell is designed for use on small to medium sized metal parts and is capable of meeting moderate production polishing demands.

### Features:

- Compact Centrifugal Disc System – high efficiency processing
- PLC/Touchscreen Control – process recipe storage & fully automated processing
- Process Monitoring Sensors – reliable, unattended processing
- Extreme ISF® Dosing Panel – automated process consumable delivery
- Ultrasonic Cleaner (included)

### Requirements:

- Power – 230V / 3 Ph / 13A
- Compressed Air – 50 PSI, 12 CFM
- Water – 30 PSI
- Footprint - ~56 x 37 x 74" (1420 x 940 x 1880 mm)



The Ramp System™ H+ Series is available for order today.

All sites are ISO 9001:2015 and AS9100:2016 Rev D certified

ISF® and REM logo are registered trademarks of REM Surface Engineering. All rights reserved.



Contact us at  
[inquires@remchem.com](mailto:inquires@remchem.com)  
for pricing and lead-time

[www.remchem.com](http://www.remchem.com)



# Ramp System™ L+ Series

## Extreme ISF® Process Cell

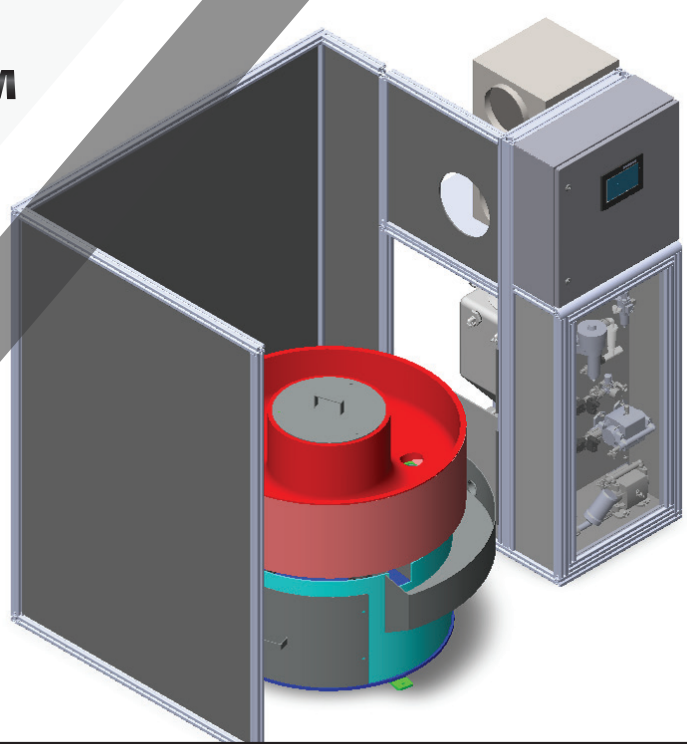

The Ramp System™ L+ Series Extreme ISF® Process Cell is designed for medium to moderately sized metal parts and is capable of meeting moderate production polishing demands.

### Features:

- Medium Size Vibratory Bowl System – broad part geometry compatibility
- PLC/Touchscreen Control – process recipe storage & fully automated processing
- Process Monitoring Sensors – reliable, unattended processing
- Extreme ISF® Dosing Panel – automated process consumable delivery

### Requirements:

- Power – 230V / 3 Ph
- Compressed Air – 50 PSI, 12 CFM
- Water – 30 PSI
- Footprint – varies based on bowl size selection

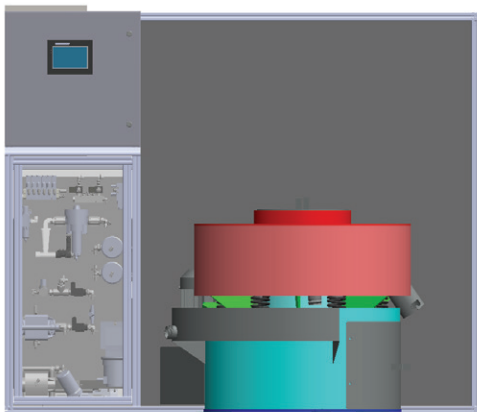

**The Ramp System™ L+ Series is available for order today.**

*All sites are ISO 9001:2015 and AS9100:2016 Rev D certified  
ISF® and REM logo are registered trademarks of REM Surface Engineering. All rights reserved.*



Contact us at  
[inquires@remchem.com](mailto:inquires@remchem.com)  
for pricing and lead-time

[www.remchem.com](http://www.remchem.com)

# Entry System™ L+ Series

## Extreme ISF® Process Cell

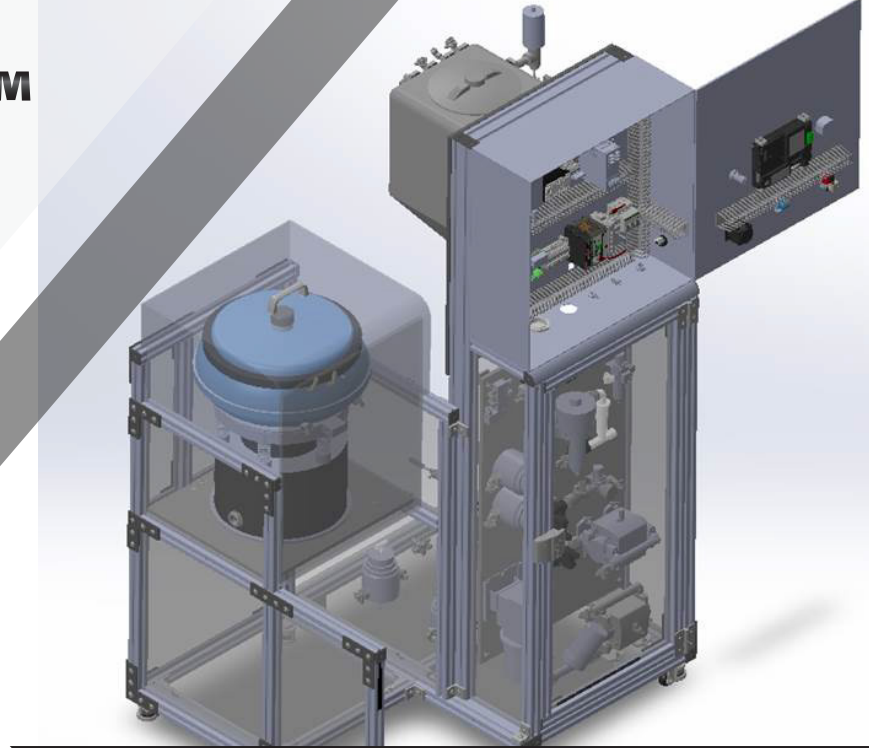

The Entry System™ L+ Series Extreme ISF® Process Cell is designed for use on small to medium sized metal parts and is capable of meeting low volume prototyping or production demands as an efficient and flexible polishing system.

### Features

- Compact Vibratory Bowl System – gentle polishing process
- PLC/Touchscreen Control – process recipe storage & fully automated processing
- Process Monitoring Sensors – reliable, unattended processing
- Extreme ISF® Dosing Panel – automated process consumable delivery

### Requirements

- Power – 230V / 3 Ph / 13A
- Compressed Air – 50 PSI, 12 CFM
- Water – 30 PSI
- Footprint - ~56 x 37 x 74" (1420 x 940 x 1880 mm)

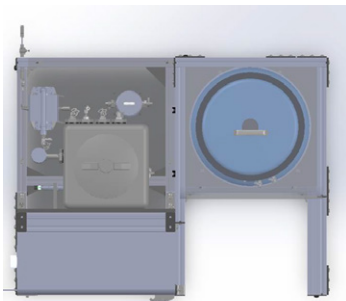

**The Entry System™ L+ Series is available for order today.**

All sites are ISO 9001:2015 and AS9100:2016 Rev D certified

ISF® and REM logo are registered trademarks of REM Surface Engineering. All rights reserved.



Contact us at  
[inquires@remchem.com](mailto:inquires@remchem.com)  
for pricing and lead-time

[www.remchem.com](http://www.remchem.com)

# Chemical Polishing

## Extreme ISF® Process Cell



REM's Extreme ISF® CP Cells™ are designed to meet your specific alloy and component processing needs. A CP Cell can be designed for a single alloy or for a range of alloys, and with multiple sizes, configurations and part handling applications REM's CP Cells are able to meet all varieties of processing needs.

### Features

- Processing Enclosure with Exterior Loading/Unloading
- Multiple Tank System
- X-Z Gantry System
- PLC/Touchscreen Control – process recipe storage
- Temperature Monitoring/Control
- Process Monitoring Sensors
- Extreme ISF® Dosing Panel – automated process consumable delivery

### Optional Add-Ons

- CP Flow Through Capability
- Alternate Processing/Work Holding Capabilities

### Requirements

- Power 480V & 240V / 3 ph
- Compressed Air – 90 PSI, 5 CFM
- Water – optional/recommended
- Footprint – varies/flexible

### A6061-RAM2 Honeycomb Lattice

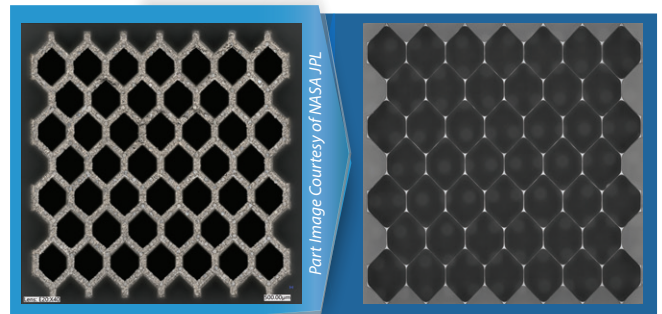

All sites are ISO 9001:2015 and AS9100:2016 Rev D certified

ISF® and REM logo are registered trademarks of REM Surface Engineering. All rights reserved.



Contact us at  
[inquires@remchem.com](mailto:inquires@remchem.com)  
for pricing and lead-time

[www.remchem.com](http://www.remchem.com)





### About REM

REM Surface Engineering is a global technology leader in providing surface engineering and polishing solutions to metal components. REM is the inventors of the ISF® Process, the Rapid ISF® Process, the Extreme ISF® Process and the REM® Process. These chemically assisted/accelerated processes are value-adding and performance-enhancing isotropic superfinishing technologies that offer unmatched benefits as compared to traditional machining, abrasive, or electrochemical processes.

REM's technologies are used on many of the most demanding applications including over 70 major aerospace platforms as well as multiple lunar and Martian rover missions. REM's technologies have been installed in hundreds of customer sites across North America, Europe, South America, Asia, Africa and Australia. All REM facilities are ISO9100 and AS9100 certified, and with over 55 years in business, REM has the capabilities, expertise, and experience to meet almost any surface finishing challenge.

REM is a third generation, family-owned business. We treat our customers as partners, and we commonly have ongoing business relationships that span multiple decades. Our focus is always to provide our customers solutions that meet or exceed their needs and expectations.

With three US sites, one UK Site and global distribution capabilities, REM is ready and able to support your surface finishing installation needs wherever they exist.

### REM Surface Engineering

325 W Queen Street  
Southington, CT 06489 USA  
Phone: (860) 621-6755  
Fax: (860) 621-8822  
Email: sales@remchem.com

### REM Surface Engineering

2107 Longwood Drive  
Brenham, TX 77833 USA  
Phone: (979) 277-9703  
Fax: (979) 277-0309  
Email: sales@remchem.com

### REM Surface Engineering

8912 Mississippi Street  
Merrillville, IN 46410 USA  
Phone: (860) 736-1477  
Email: sales@remchem.com

### REM Surface Engineering, Ltd.

Alington Road, Little Barford  
Cambridgeshire PE19 6YH UK  
Phone: +44 (0) 1480 210756  
Fax: +44 (0) 1480 476339  
Email: sales-eu@remchem.com

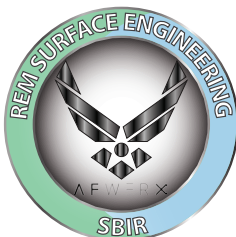

All sites are ISO 9001:2015 and AS9100:2016 Rev D certified

ISF® and REM logo are registered trademarks of REM Surface Engineering. All rights reserved.



Contact us at  
[inquires@remchem.com](mailto:inquires@remchem.com)  
for pricing and lead-time

[www.remchem.com](http://www.remchem.com)